



The magnification of force that occurs when force is transferred from a wheel to an axle is what creates the mechanical advantage of this simple machine. Door knobs and screwdrivers are examples of tools that make use of the mechanical advantage of a wheel and axle. Both receive a manually applied force at one end—the wheel end—and magnify the force at the other end—the axle end—to complete the task.

## ▼ Activity Sheet 5

### The Wheel and Axle

1. Assemble your tractor according to your teacher's instructions. Roll it forward and backward. What simple machine allows it to roll?  
the wheel and axle
2. Draw a picture to show how the wheel connects to the axle.  
Drawings should show the axle inserted in the hole in the center of the wheel.
3. Complete the following sentence: I predict that it will take more (less) force to wind the rubber band around the axle three times using the wheel. (Circle one.)
4. Once you have finished the experiment, complete the following statements according to what you observed.  
As distance increases, force decreases .  
As distance decreases, force increases .
5. Using the piece of string, measure the circumference of the handle and the shaft of the screwdriver. Record your measurements below.  
a. Handle Circumference (cm) 7-10    b. Shaft Circumference (cm) 2-3
6. What happens to the force as it is transferred from the handle of the screwdriver to the shaft?  
Because the circumference of the shaft is smaller than that of the handle, the force is magnified as it travels from the handle to the shaft.
7. Which statement in question 4 above applies to your explanation of how force is transferred in the screwdriver?  
As distance decreases, force increases.
8. How does this mechanical advantage help you to drive a screw into a board?  
Because the force felt by the screw is magnified at the end of the screwdriver shaft, I only have to supply a relatively small force on the handle in order to turn the screw.

## Guiding the Activity

- 1 Distribute a pair of safety goggles and a copy of **Activity Sheet 5** to each student. Distribute a tractor kit, a short rubber band, a long rubber band, two wide rubber bands, and a piece of masking tape to each team of four.

Have the teams assemble their tractors. Tell them to insert the large axle through the larger holes in the frame and attach a large wheel to each end of this axle. They should then insert the small axle through the smaller holes in the frame and attach a small wheel to each end of this axle. Have teams fit a wide rubber band (a “tire”) around each of the two large (rear) wheels.

Next, have them insert the peg into the hole in the large axle and push it in all the way so that it is flush on one side and sticks out on the other. They should then put a small piece of masking tape over the end of the peg that is flush with the axle.

## Additional Information

*The wheels should fit snugly on the axles. If necessary, have students lightly sand the ends of the axles so they will fit into the wheels.*

## Guiding the Activity

Finally, tell the students to screw the smaller screw-eye into the hole near the small axle and the larger screw-eye into the hole at the rear of the frame (see Figure 5-1).

## Additional Information

*Make sure that students screw in the screw-eyes all the way so that the tension from the rubber band will not dislodge them.*

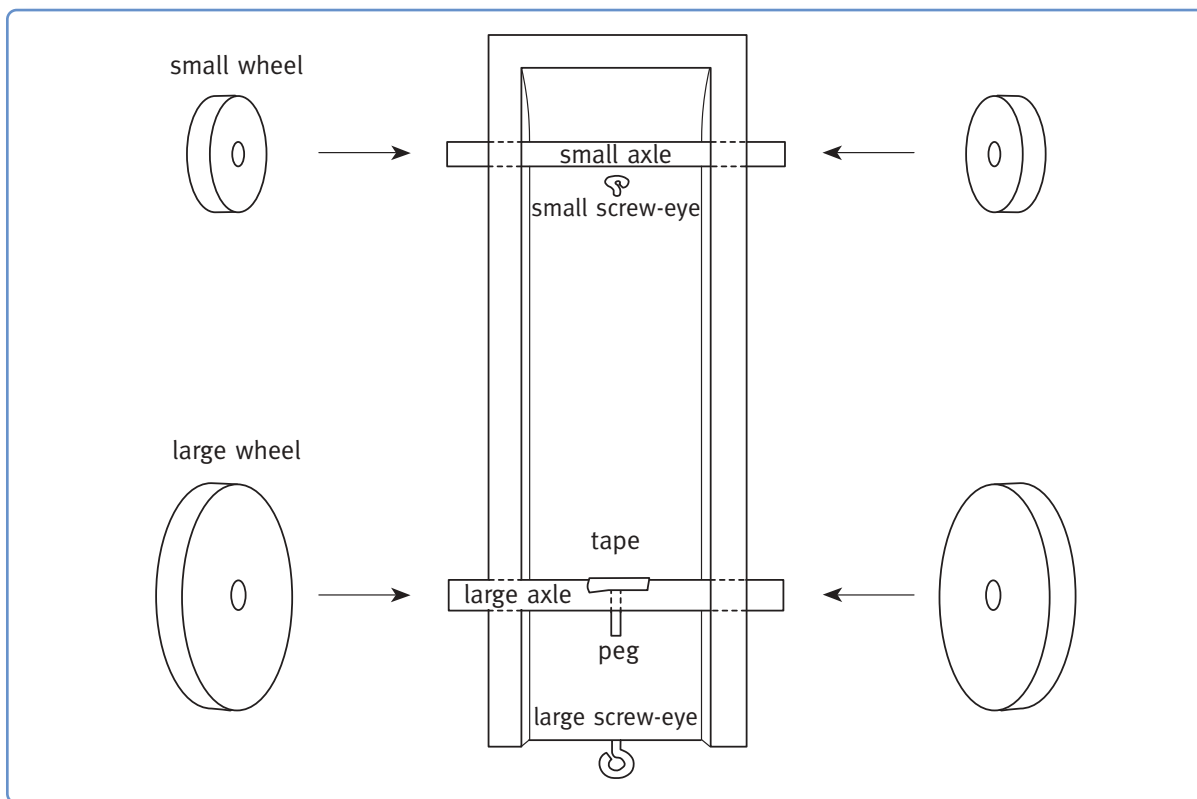

▲ *Figure 5-1. Assembling the tractor.*

2

Write the word *axle* on the board. Explain that an **axle** is a shaft to which one or more wheels is attached. An axle is smaller in diameter than the wheel, but because it is inserted into the center of the wheel, each revolution of the axle causes the wheel to make one complete revolution, and vice versa.

Ask, **Why do you think it is important that the axles rotate freely in the holes in the frame?**

Allow students time to experiment with their tractors and observe the function of the wheel and axle as a unit. Tell them that their tractors are able to roll because of a simple machine called the wheel and axle.

*To reduce the friction between the axle and the frame of the tractor.*

*Have students complete questions 1 and 2 of their activity sheets.*

## Guiding the Activity

## Additional Information

**Safety Note:** Tell students to wear their safety goggles whenever they are winding the rubber bands.

- 3 Have students attach a long rubber band to the smaller screw-eye and the wooden peg on the rear axle, as shown in Figure 5-2. Have them wind the rubber band around the axle by rotating the rear wheels backward three full turns.

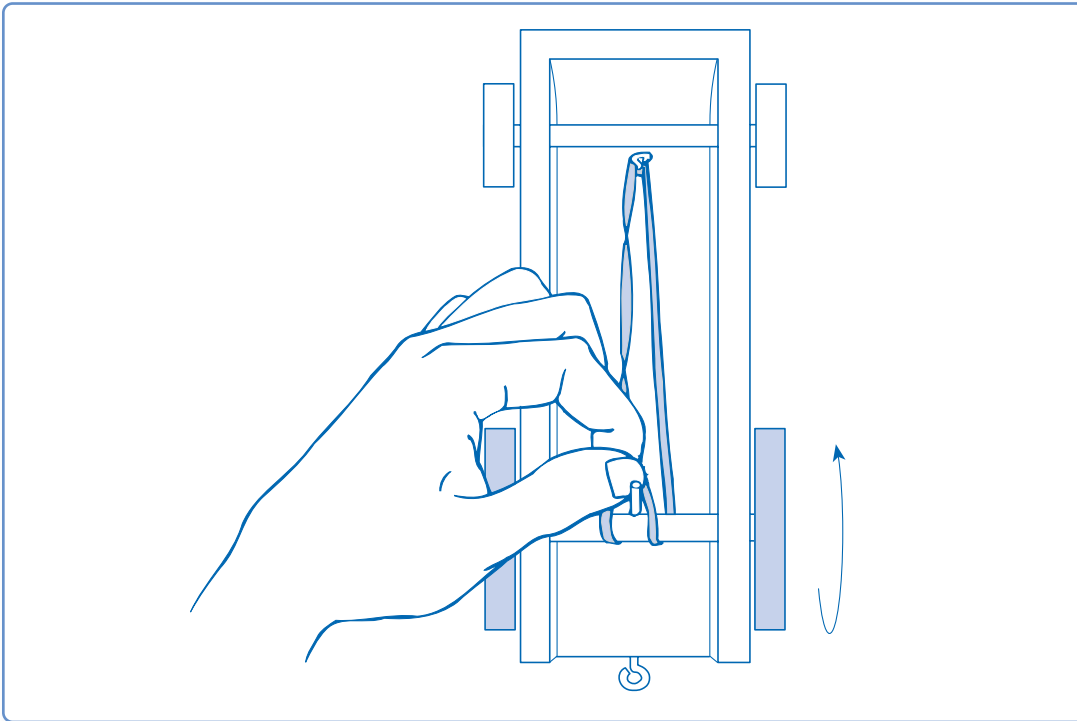

▲ Figure 5-2. Winding the rubber band around the rear axle.

Ask, **What are you doing as you wind up the rubber band?**

Ask, **What is the force that is being applied? Where is the force stored?**

Encourage answers that relate to doing work.

The student winding the rubber band around the axle is supplying the force. The force is stored in the rubber band that is wrapped around the axle.

- 4 Have students set their “wound-up” tractors on the floor and let them go. After all of the tractors have come to a stop, ask, **Where did the force to move the wheels forward come from?**

Ask, **Over what distance was the force applied?**

It was transferred from the axle to the wheels.

Over the distance of the circumference of the wheel. If students do not know what circumference is, explain it to them. (The perimeter of a circle.)

## Guiding the Activity

- 5 Write the following equation on the board:

$$W = F \times d$$

Tell students that, as the tractor rolls, the amount of work performed by the axle as it turns is the same as the amount of work performed by the wheel as it rolls. In other words, the amount of work remains constant, even as the force is transferred from axle to wheel.

Point to the letter  $d$  in the equation and ask, **If the circumference of the wheel is larger than the circumference of the axle, what happens to the amount of force transferred to the wheel?**

Tell students that they will conduct an experiment to find out whether force increases or decreases when it is transferred from the axle to the wheel. To do this, they will look at how much force is needed to perform a certain amount of work using first the axle, and then the wheel.

- 6 Have students turn their tractors upside-down, remove the large rubber band, and attach the short rubber band to the wooden peg on the rear axle and the larger screw-eye at the rear of the tractor.

Tell them that they will wind the rubber band around the axle like they did before, but they will do it twice this time: once using the wheel to make the three rotations, and once using the axle to make the rotations. They will then compare the relative amount of force it took to wind the rubber band using the axle with the amount it took using the wheel.

Have them answer question 3 on their activity sheets.

## Additional Information

*Remind students of what each letter stands for:  $W$  = work,  $F$  = force, and  $d$  = distance.*

*For the amount of work to remain constant, force must decrease. (If students do not see the relationship between the circumference of the wheel and  $d$ , point it out to them.) If students cannot deduce that force must decrease, do not disclose the information yet.*

*Point out to students that, although the question has been rephrased, they are still testing the same principle. (If  $W$  stays constant and  $d$  is changed, what happens to  $F$ ?)*

## Guiding the Activity

Ask, **Will you be performing the same amount of work in both cases?**

Ask, **Why is it important that you perform the same amount of work in both cases?**

## Additional Information

*Because they will rotate the axle and wheel three times in both cases, the amount of work that they perform will be the same.*

*If students do not know, point out that they can only compare force used on the wheel to force used on the axle if they perform the same amount of work on each.*

*Tell students they may remove one rear wheel to turn the axle. The students doing the turning should use two fingers of one hand to turn, and two fingers of the other hand to hold the other end of the axle in place between rotations.*

7

Have team members take turns holding the tractor body still while another team member turns the axle (or wheel) three rotations (see Figure 5-3, parts a and b).

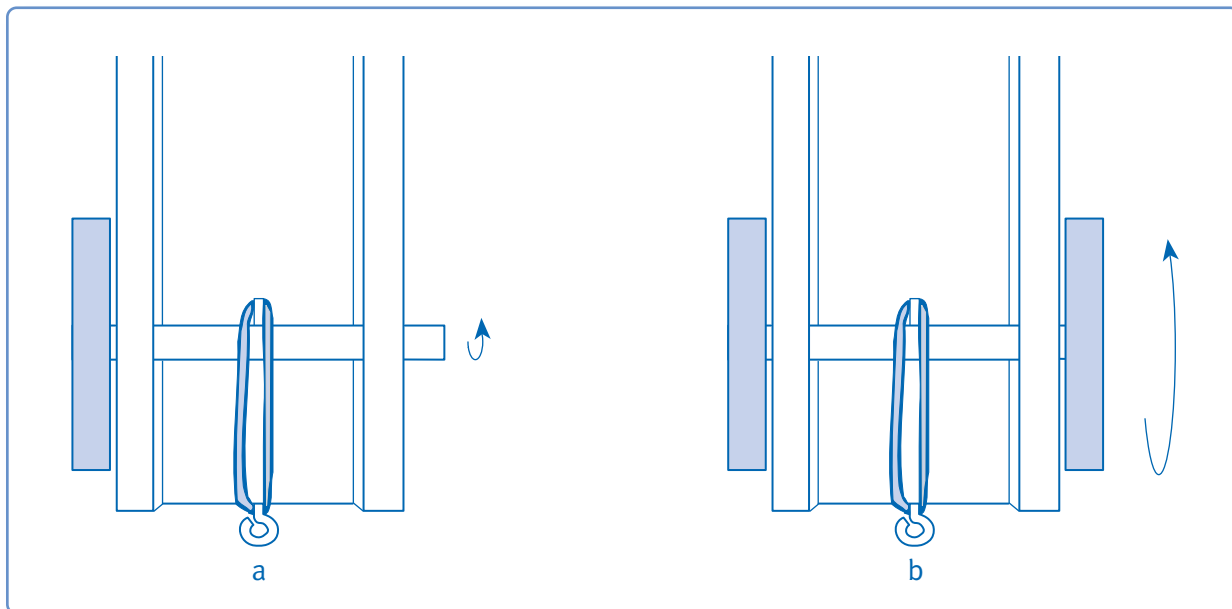

▲ *Figure 5-3. Turning the axle (a) and turning the wheel (b). Figure shows right-hand bias.*

When students have finished, ask, **Was it easier to wind the rubber band by turning the wheel or by turning the axle? Which required less force?**

Bring their attention back to the equation on the board. Ask, **Was your prediction correct?**

*It took less force to wind the rubber band by turning the wheel than by turning the axle.*

*Student responses will vary, depending on their predictions.*

## Guiding the Activity

Explain that as  $d$  increases,  $F$  decreases. Because the circumference of the wheel is bigger than the circumference of the axle, the force they need to apply to turn the wheel three rotations is distributed over a greater distance, and therefore the force needed to turn it is decreased.

Ask, **Do you think it would be harder or easier to wind the rubber band using a bigger wheel?**

**8** Explain that just as a force is decreased as it is transferred from an axle to a wheel, so it is magnified when transferred from a wheel to an axle. Tell students that this magnification of force creates a mechanical advantage.

Ask, **What household tool uses the mechanical advantage of a wheel and axle?**

Explain that the screwdriver handle is like a wheel (larger in circumference) and the shaft is like an axle (smaller in circumference).

**9** Distribute a screwdriver, a metric ruler, and a piece of string to each team. Have students use the string and ruler to measure the circumference of the handle and the shaft of the screwdriver. Tell them to record their results on their activity sheets.

Return their attention to the equation on the board ( $W = F \times d$ ). Ask students to explain on their activity sheets what happens to the force as it is transferred from the handle (where it is applied) to the end of the shaft (where it is used to turn a screw).

Tell students that they will explore the mechanical advantage of screws in a later activity.

Have students answer questions 7 and 8 on their activity sheets.

## Additional Information

*Tell students to complete question 4 on their activity sheets.*

*Students should recognize that the bigger the wheel, the smaller the force needed to rotate it.*

*If students do not suggest it, hold up a screwdriver.*

*If necessary, show students how to use the string to measure the circumference of the screwdriver handle and shaft.*

*Remind them to use the terms in the equation  $W = F \times d$  in their explanations.*

## REINFORCEMENT

If students are having trouble understanding that  $d$  is increased as you move from axle to wheel, have them conduct the following test.

Tell them to draw a thin line from the center to the edge of the axle end (located inside the center of the wheel). Have them set their tractors down on a desktop and roll them forward until they see the line on the axle make one full rotation. Tell them to measure the distance the tractor moved. Then have them use the string to measure the circumference of the wheel. They will find that they are the same length. Students should also recognize that the axle moved only a small distance (the distance of its circumference), whereas the wheel moved a greater distance for the same amount of work (one rotation).

## SCIENCE JOURNALS

Have students place their completed activity sheets in their science journals.

## CLEANUP

Tell students to remove the short rubber band from their tractors but to leave the wide rubber bands on the rear wheels. Have them return the assembled tractors, string, and long and short rubber bands to the kit.

## SCIENCE AT HOME

Divide students into teams and ask each team to look for wheels and axles at home. See which team can find the most wheel and axle machines. Have the teams share their findings with the class.

## Connections

### Science Challenge

Explain that a wheel with its axle placed off-center is called a *cam*. Cams are used in engines to move levers at regular intervals. In a car engine, for example, cams operate levers that open and close the engine valves. Have students use a variety of materials to make cams that move levers. Let them experiment freely, then compare their devices with illustrations of cams in physics textbooks and other sources.

### Science Extension

- ▶ Make sure students understand that the wheel and axle is used in many other applications as well. Remind them of the windlasses they made in the Science Extension connection for Activity 4. Ask students to find other examples of the wheel and axle in daily life—for example, the handle of a water faucet and a wrench used to turn an object.
- ▶ Tell students that a wheel can be thought of as a series of levers rotating around a central fulcrum. To demonstrate this, have students attach four drinking straws to a foam plastic plate with a nail pushed through the center of the straws and plate. Tell students to space the straws evenly and then tape the ends to the plate. Then have students hold the nail protruding from the back of the plate, put a finger against the end of one straw, and turn the plate slowly. Students will see that the straws function as levers that continuously “tip” in one direction. If students have difficulty perceiving this, have them color each straw a different color.

### Science and Social Studies

Three other examples of the wheel and axle are the windmill, the paddle wheel, and the waterwheel. Encourage students to research the use of these devices through history to modern times. Ask them to find out how the rotation of a windmill or waterwheel is used to drive other wheels and parts to perform a task such as grinding corn, sawing lumber, or generating electricity. Suggest that students investigate the different types of waterwheels (undershot, overshot, and breast wheels) and the advantages and applications of each type. Also encourage students to build model windmills, paddle-wheel boats, and waterwheels following instructions they have found in science activity books.

### Science, Technology, and Society

- ▶ Ask students to explain what inertia is (the tendency of a stationary object to remain at rest or of a moving object to remain in motion). Explain that a *flywheel* is a heavy wheel used in an engine or machine to help keep an object in motion. Ask students to research and report on examples of flywheels, such as the flywheel in a car engine and the lower horizontal flywheel in a potter’s wheel. The operation of a flywheel can be demonstrated with a small “friction” toy car, in which energy is stored in a flywheel by rubbing the car against the floor in one direction several times before letting the car go.
- ▶ Encourage interested students to research and report on a *differential*—a device used in automobiles to allow the wheels on each axle to rotate at different speeds when the automobile turns a corner. Why is a differential needed? How does it operate? Students might be able to build a working model to demonstrate to the class.